

MACCHINE AGRICOLE

ORTOLAN
ANDREA

TRINCIASARMENTI
MULCHER



50/100 HP (37/74 KW)



160 > 250 cm

TSF



CE

Ideale per la pulizia di bordi stradali, fossati, ripe, prati, frutteti e vigneti.

Ideal for cleaning street sides, dykes, steep banks, meadows, orchards and vineyards.





50/100 HP (37/74 KW)



160 > 250 cm

TSF



Attrezzatura caratterizzata dalla versatilità d'impiego. Può essere utilizzata per la trinciatura posteriore e per il lavoro in posizione laterale. Ideale per la pulizia di bordi stradali, fossati, ripe, prati, frutteti e vigneti.

Moltiplicatore con ruota libera • Trasmissione a cinghie trapezoidali • Rullo posteriore regolabile • Rotore bilanciato elettronicamente • Elevata velocità periferica delle mazze • Attacco universale a 3 punti di II° cat. • Sistema idraulico anti-urto • Sostegno per albero cardanico • Cofano apribile per manutenzione

OPTIONAL: Gruppo moltiplicatore esterno • Albero caedanico • Coppia di slitte.



This versatile machine can be used for rear shredding and for lateral working, which are ideal for cleaning street side dykes, steep banks, meadows, orchards and vineyards.

Gearbox with free-wheel • Transmission with trapezoidal belts • Adjustable rear roller • Electronically balanced rotor • High peripheral speed of the hammers • Universal three-point hitch cat. 2 • Hydraulic antishock system • Cardan shaft support • Openable bonnet for maintenance

OPTIONAL: Externally positioned gearbox • Cardan shaft • Pair of skids

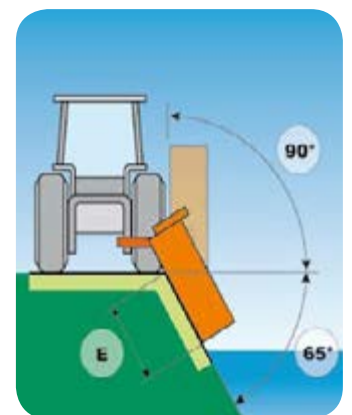
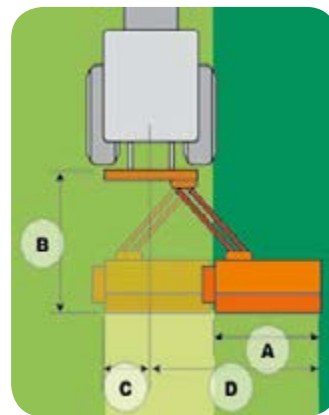
**VERSIONE STANDARD / STANDARD VERSION**

Modello Model	Largh. lavoro Working width	Ingombro Total width	Peso Weight	HP (KW)	Mazze Hammers	Coltelli Blades	A (cm)	B (cm)	C (cm)	D (cm)	E (cm)
TSF 160	160 cm	175 cm	715 kg	55/100 (40/74)	18	36	160	168	85	234	145
TSF 180	180 cm	195 cm	751 kg	60/100 (44/74)	20	40	180	168	85	254	165
TSF 200	200 cm	215 cm	787 kg	70/100 (51/74)	24	48	200	168	85	274	185
TSF 220	220 cm	235 cm	823 kg	80/100 (59/74)	26	52	220	168	85	294	205
TSF 250	250 cm	265 cm	860 kg	90/100 (66/74)	28	56	250	168	85	314	235

VERSIONE CON SCATOLA ESTERNA / EXTERNAL GEARBOX VERSION

Modello Model	Largh. lavoro Working width	Ingombro Total width	Peso Weight	HP (KW)	Mazze Hammers	Coltelli Blades	A (cm)	B (cm)	C (cm)	D (cm)	E (cm)
TSF 160	160 cm	175 cm	715 kg	55/100 (40/74)	18	36	160	168	55	264	175
TSF 180	180 cm	195 cm	751 kg	60/100 (44/74)	20	40	180	168	55	284	195
TSF 200	200 cm	215 cm	787 kg	70/100 (51/74)	24	48	200	168	55	304	215
TSF 220	220 cm	235 cm	823 kg	80/100 (59/74)	26	52	220	168	55	324	235
TSF 250	250 cm	265 cm	860 kg	90/100 (66/74)	28	56	250	168	55	344	265

DTSF800 - I dati e le illustrazioni sono indicativi. Ci riserviamo il diritto di modifica senza obbligo di preavviso.
Data and illustrations are indicative. We reserve the right to edit the contents of this catalogue without obligation to notice.



FOLLOW US



ORTOLAN ANDREA macchine agricole | Via Lungochiampo, 90 | MONTEBELLO (VI) | ITALY
Tel. e Fax +39 0444 440960 | info@ortolanandrea.it | www.ortolanandrea.it